

Linea Imperiale



CIRENE LI-500

WWW.LINEAIMPERIALE.COM

In collaboration with Italy's renowned designer and historian "Giovanni Sanremo" we have created an Imperial Line made for the needs of the most demanding consumers that search for the best.

You will find many models to choose from all offering their own unique history and character designed specifically for your solid surface counter top. All sinks include exclusive accessories made to enhance your kitchen as to provide the most efficient working environment possible. Thank you again and enjoy your new "Linea Imperiale" sink and faucet by C-TECH-I.



FEATURES

Model #	LI-500
Description	SINGLE BOWL KITCHEN SINK
Material	PREMIUM 18/10 304 STAINLESS STEEL
Color	STAINLESS STEEL
Mounting options	UNDER-MOUNT
Finish	BOWLS BRUSHED AND SURFACE POLISHED
Thickness	16 GAUGE
Sound proofing	10 POINT SOUND PAD SYSTEM
Construction type	ONE PIECE CONSTRUCTION
Construction method	PRESSED 3 TIMES
Warranty	LIMITED LIFETIME
Overflow	NO
Drain size	3 5/8", STANDARD USA, CA AND EUROPE SIZE
Certifications	CAN/CSA-B45/ANSI-A112.19/ANSI-Z124/MASS
FGP Compliant	YES
Fits cabinet size	MADE FOR CABINETS 18" AND LARGER

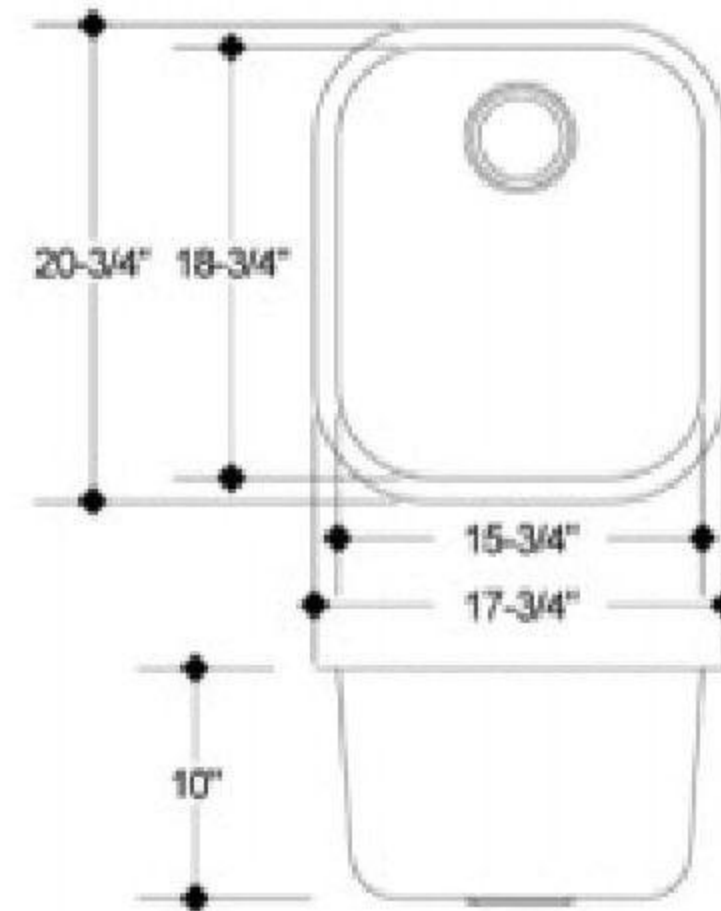

INCLUSIONS:

- Your Linea Imperial sink includes the following accessories,
- Paper template for cut-out
- Mounting hardware
- Set of bottom strainer/grids to protect your sink bottom
- One deluxe deep drain with retractable basket
- One stainless steel pasta strainer

